

**DIVISION: 05 00 00—METALS**  
**Section: 05 52 00—Metal Railings**

**REPORT HOLDER:**

**ARIA**

**EVALUATION SUBJECT:**

**ALUMINUM RAILING SYSTEM SERIES A800**

**1.0 EVALUATION SCOPE**

**Compliance with the following codes:**

- 2015, 2012, 2009, and 2006 *International Residential Code*® (IRC)

**Property evaluated:**

Structural

**2.0 USES**

The Aluminum Railing System Series A800 described in this report are limited to exterior or interior use as a guardrail system for balconies, porches, and decks for one- and two-family dwellings constructed in accordance with the IRC.

**3.0 DESCRIPTION**

**3.1 General:**

The Aluminum Railing System Series A800 are guards consisting of extruded aluminum posts, sub-rail panel with top and bottom channel rails and balusters, bottom-rail support leg, and top and bottom rail covers. The Aluminum Railing System components are produced from 6063-T5 aluminum alloy, the posts are produced from 6005A-T5 aluminum alloy, and the post caps and post base plates are produced from A380 aluminum alloy. The Aluminum Railing System Series A800 is described by a designated series: Aria (A). The minimum yield and tensile strengths, minimum thickness of the railing components, and manufacturing extrusion process are specified in accordance with the approved quality control documentation. The railing components are available in a white, black or bronze powder coated finish.

**3.2 Guard:**

The height of the railing assembly is 42 inches (1067 mm) above the walking surface. The top rail cover has a wall thickness of 0.055-inch (1.40 mm); and the overall top rail width is 2½-inches (63.5 mm), and the overall top rail depth is 2.25-inches (57.2 mm).

The bottom rail cover has a wall thickness of 0.055-inch (1.40 mm), a width of 1½-inches (38.1 mm), and a depth of 1½-inches (38.1 mm). For the sub-rail panels, both top and bottom h-channel rails having varying wall thicknesses between 0.065-inch (1.65 mm) and 0.083-inch (2.11 mm) thick, a width of 1.38-inches (35.1 mm), and a depth of 0.97-inch (24.6 mm). Both top and bottom rail covers and sub-rail panels are available in 8-foot (2.44 m) lengths. They are produced from 6063-T5 aluminum alloy and come in a powder coated finish. The maximum railing span for each Aluminum Railing System series is noted in Table 1.

The pickets are hollow rectangular extruded 6063-T5 aluminum. The pickets have a wall thickness of 0.050-inch (1.27 mm), a width of ½-inch (12.7 mm), and a depth of ¾-inch (19.1 mm) and come in a powder coated finish. Each picket is inserted in the pre-punched holes on the top and bottom h-channel rails of each sub-rail panel, with a center-to-center spacing of 4½-inches (114.3 mm).

The posts are 3-inches (76.2 mm) square hollow extruded 6005A-T5 aluminum with a wall thickness of 0.065-inch (1.65 mm) and come in a powder coated finish. The post cap is produced from A380 aluminum alloy and is installed at the top of the extruded post and measures 3-inches (76.2 mm) by 3-inches (76.2 mm) square. The post base plate is produced from A380 aluminum alloy and is installed at the bottom of the extruded post; it measures 4.99-inches (126.7 mm) by 4.99-inches (126.7 mm) square. The 8-foot (2.44 m) railing system utilizes one intermediate bottom rail support leg located at the midspan. Each support leg is a 1½-inch (38.1 mm) square hollow extruded 6063-T5 aluminum with a wall thickness of 0.052-inch (1.32 mm) and comes in a powder coated finish.

The top and bottom rail connector clips are made from 0.080-inch (2.03 mm) thick 5052-H32 aluminum sheets and measures 1-inch (25.4 mm) wide by 0.94-inch (23.9 mm) long by 0.060-inch (1.52 mm) deep, with two 0.16-inch (4.06 mm) diameter holes for securing into the post.

See Figure 1 for details of the components for the aluminum railing system.

**4.0 DESIGN AND INSTALLATION**

**4.1 Design:**

The Aluminum Railing System Series A800 is satisfactory to resist loads specified in IRC Table R301.5, when installed at the maximum clear distance between the posts as noted in Table 1. When the railing

is supported on one or both ends by the supporting structure, the maximum clear distance between the post and the supporting structure or between the supporting structures must comply with the spans noted in Table 1.

**4.2 Installation:**

Installation must be in accordance with the manufacturer’s published installation instructions, this report, and guard height and opening limitations provisions specified in IRC Section R312. The manufacturer’s published installation instructions must be available at the jobsite at all times during installation.

Each top and bottom rail cover snaps over the sub-rail panel’s corresponding top and bottom h-channel rails. The pickets are inserted into the pre-punched holes on the top and bottom h-channel rails of the sub-rail panel. The sub-rail panel is then attached to an extrusion post on each end by installing top and bottom rail connector clips with #8 x 3/4-inch (19.05 mm) long stainless steel TEK screws. Four screws (two inside and one on each side) per each top and bottom connector clip, as shown in Figure 1. The bottom rail connector clip must be located 3 3/4-inches (95.25 mm) from the top edge of the clip to the bottom of the post extrusion at center. All connector clips must be installed with two #8 x 3/4-inch (19.05 mm) long stainless steel TEK screws. Each support leg is fastened at the midspan of the bottom rail with one #8 x 3/4-inch-long (19.05 mm) stainless steel TEK screw. Each extruded post is attached to a post base plate with four M8 x 80 mm long stainless steel lag screws, which are fastened on the underside of the post base plate, as shown in Figure 1.

**5.0 CONDITIONS OF USE**

The Aluminum Railing System Series A800 described in this report comply with, or are a suitable alternative to what is specified in, those codes listed in Section 1.0 of this report, subject to the following conditions:

- 5.1 This product is limited to exterior or interior use as a guardrail system for balconies, porches, and decks for one- and two-family dwellings constructed in accordance with the IRC.
- 5.2 Installation must comply with this report, the manufacturer’s published installation instructions and the applicable code. When the manufacturer’s published installation instructions differ from this report, this report governs.
- 5.3 Only those fasteners and fastener configurations described in this report have been evaluated for the

installation of the Aluminum Railing System Series A800. The compatibility of the post base plate’s fasteners with the supporting construction, including chemically treated wood, is outside the scope of this report.

- 5.4 The Aluminum Railing System Series A800 must be directly fastened to supporting construction having adequate strength and stiffness. Where required by the code official, engineering calculations and construction documents consistent with this report must be submitted for approval. The calculations must verify that the supporting construction complies with the applicable building code requirements and is adequate to resist the loads imparted upon it from the products and systems discussed in this report. The documents must contain details of the attachment to the supporting structure consistent with the requirements of this report. The documents must be prepared by a registered design professional where required by the statutes of the jurisdiction in which the project is to be constructed.
- 5.5 The top rail of the Aluminum Railing System, for use as a handrail, is outside the scope of this report.

**6.0 EVIDENCE SUBMITTED**

Data in accordance with the ICC-ES Acceptance Criteria for Handrails and Guards (AC273), dated June 2017.

**7.0 IDENTIFICATION**

- 7.1 The Aluminum Railing System Series A800 described in this report are identified by a stamp, on each individual piece or on the packaging, bearing the report holder’s name (Aria), the product name (Aluminum Railing System Series A800), the allowable span, and the ICC-ES evaluation report number (ESR-4224).

The label shall also include the phrase “For Use in One- and Two-Family Dwellings Only.”

- 7.2 The report holder’s contact information is the following:

**ARIA**  
**2955 LONE OAK DRIVE, SUITE 180**  
**EAGAN, MINNESOTA 55121**

**TABLE 1—MAXIMUM GUARDRAIL SYSTEM SPAN**

PRODUCT NAME	APPLICABLE BUILDING CODE	MAXIMUM SPAN (in)
	IRC	
A800	YES	96

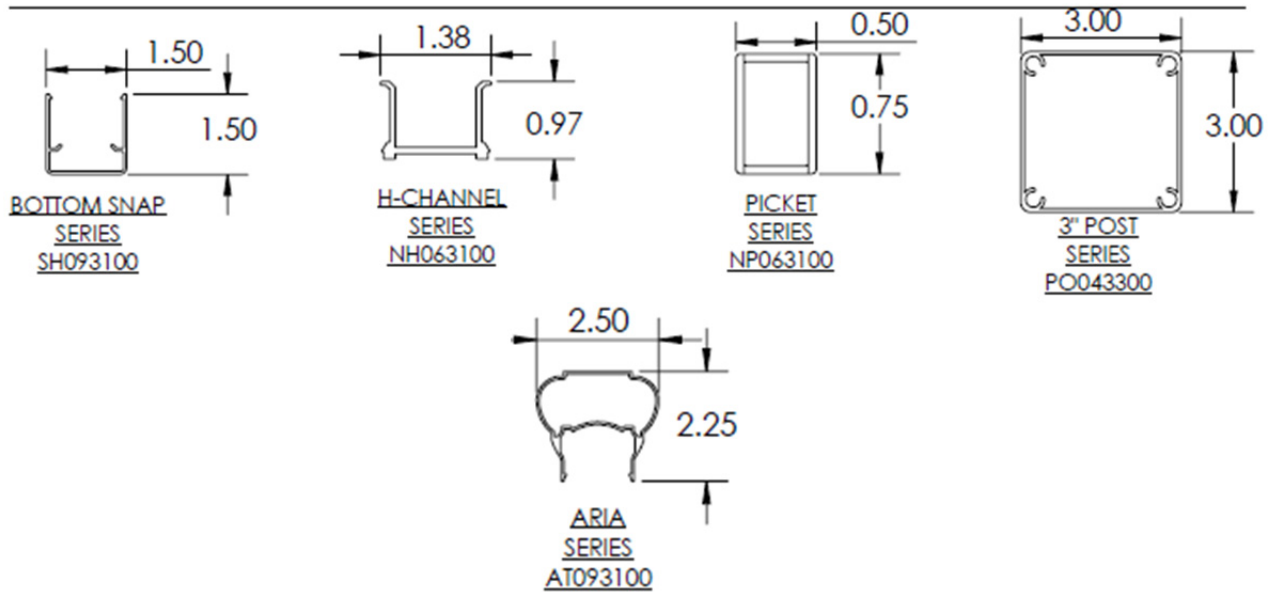
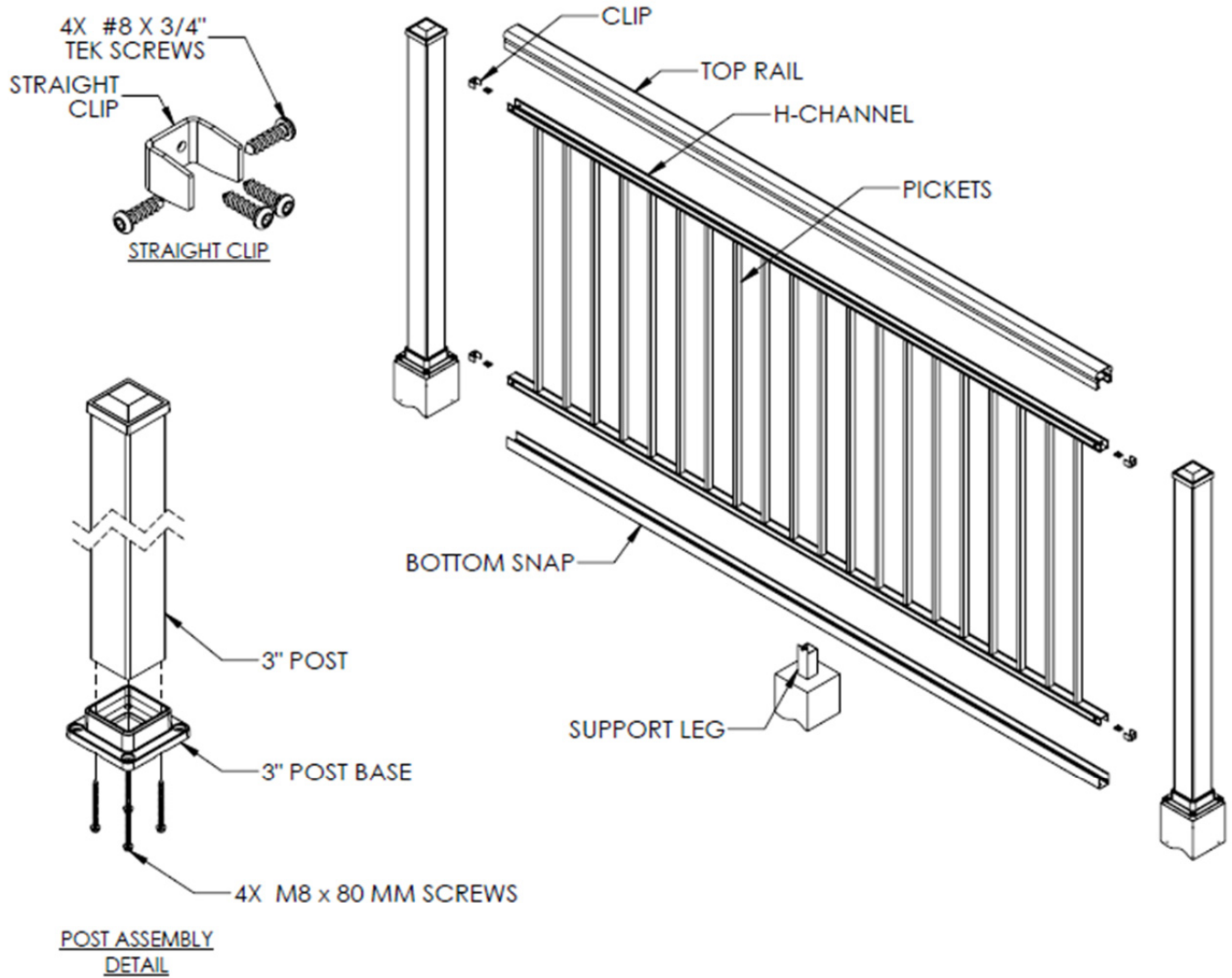

FIGURE 1—TYPICAL GUARDRAIL ASSEMBLY AND COMPONENT PROFILES

**DIVISION: 05 00 00—METALS**  
**Section: 05 52 00—Metal Railings**

**REPORT HOLDER:**

ARIA

**EVALUATION SUBJECT:**

ALUMINUM RAILING SYSTEM SERIES A800

**1.0 REPORT PURPOSE AND SCOPE****Purpose:**

The purpose of this evaluation report supplement is to indicate that the Aluminum Railing System Series A800 recognized in ICC-ES master evaluation report ESR-4224 has also been evaluated for compliance with the codes noted below.

**Applicable code edition:***2017 Florida Building Code—Residential***2.0 CONCLUSIONS**

The Aluminum Railing System Series A800 described in Sections 2.0 through 7.0 of the master evaluation report ESR-4224, complies with the *Florida Building Code—Residential*, provided the design and installation are in accordance with the 2015 *International Residential Code*® provisions noted in the master report.

Use of the Aluminum Railing System Series A800 for compliance with the High-Velocity Hurricane Zone provisions of the *Florida Building Code—Residential* has not been evaluated and is outside the scope of this evaluation report.

For products falling under Florida Rule 9N-3, verification that the report holder's quality assurance program is audited by a quality assurance entity approved by the Florida Building Commission for the type of inspections being conducted is the responsibility of an approved validation entity (or the code official, when the report holder does not possess an approval by the Commission).

This supplement expires concurrently with the evaluation report, reissued December 2019.